



CLAMPING AND BRAKING ELEMENTS FOR LINEAR GUIDES AND RODS

PNEUMATIC AND MANUAL UNITS

2018/2019



ERRE DI



ERRE DI

ERRE.DI. Automation has been manufacturing and supplying quality automation components and systems for over 20 years.

Within its own facilities, ERRE.DI. is able to design, produce and test an extensive range of clamping and braking elements for linear guides and rods.

Through its new automation line, ERRE.DI. can easily meet the market's requirements for quality and safety, responding to every technical and design problem thanks to the expertise of its engineering department.

In addition to the standard production, ERRE.DI. provides tailor-made solutions to best meet the customers' needs.

High technology production, reliability of components, technical support make ERRE.DI. the ideal partner for every industrial sector, including aerospace, robotics, machine tool, automotive, industrial automation, packaging and material handling.

CLAMPING AND BRAKING ELEMENTS FOR LINEAR GUIDES AND RODS

Pneumatic and Manual Units

Having gone through an adequate period of design, analysis, development and testing, ERRE.DI. is able to offer clamping and braking elements for linear guides and rods with the following characteristics:

- High clamping force with minimum space required
- Easy installation
- Both elements working in single or double effect need the same installation space
- The "Normally Closed" devices can be used as safety elements (clamping without air pressure)
- High switching speed Open/Closed
- Italian technology

All the clamping and braking elements undergo galvanic treatments to protect against corrosion: hard anodizing for Aluminum elements and electrolytic nickel plating bath for Steel elements.

The clamping elements - FRC, FRCDP, FRCDPH, FRCMC, FRCC and FRCBS line (SEM Operating Type) satisfy all the essential requirements of safety of the Directive 2006/42/EC.

Harmonised standard applied: EN ISO 13849.

FIELDS OF APPLICATION:

- Woodworking machine
- Metal working machine
- Glass working machine
- Packaging machinery
- Automation and Robotics
- Handling systems



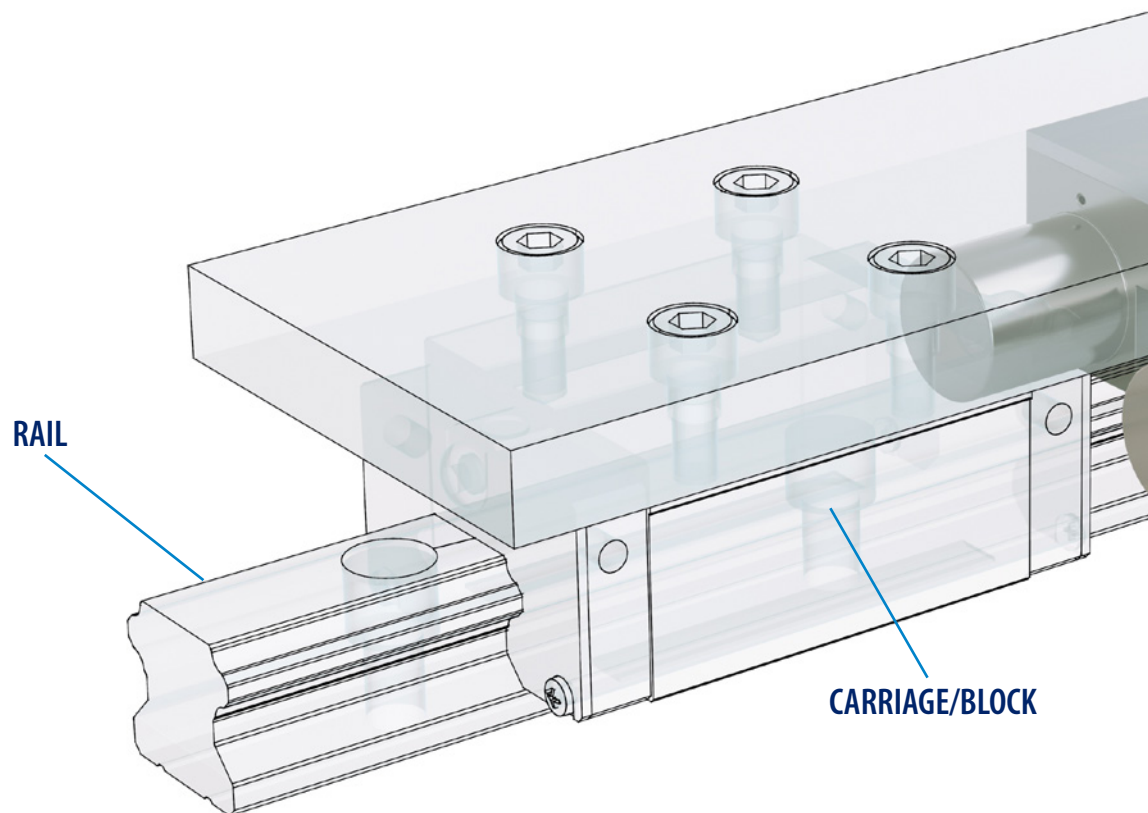

Codes for clamping and braking elements are composed as follows:

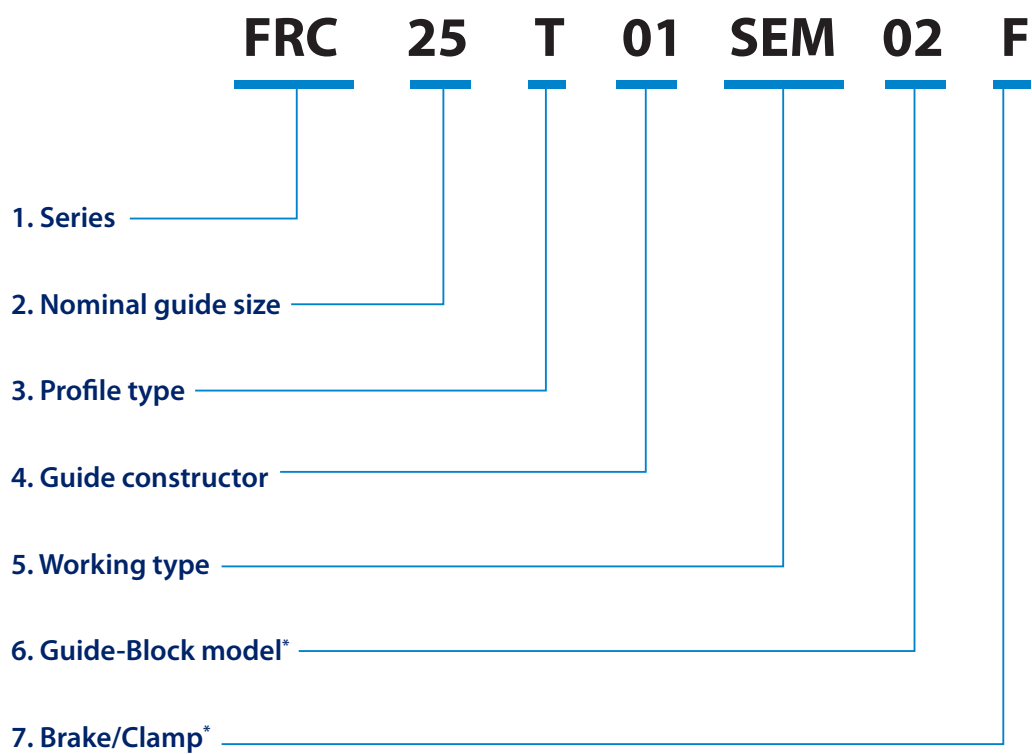

*If the code doesn't include the last two values, the element is considered as a standard clamping element (01B)

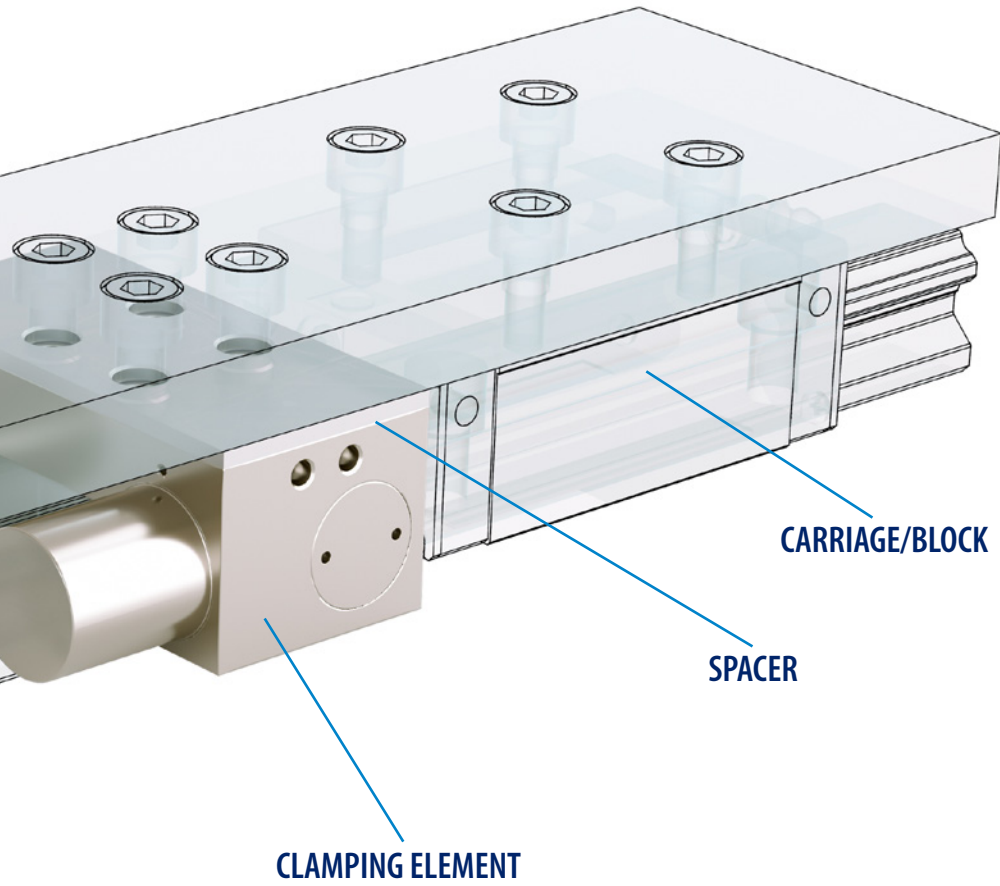

Clamping and braking elements can optionally be supplied with a “spacer” plate made in Steel, used to align the height of the element with the height of the sliding guides.

Codes for the spacer are composed as follows:

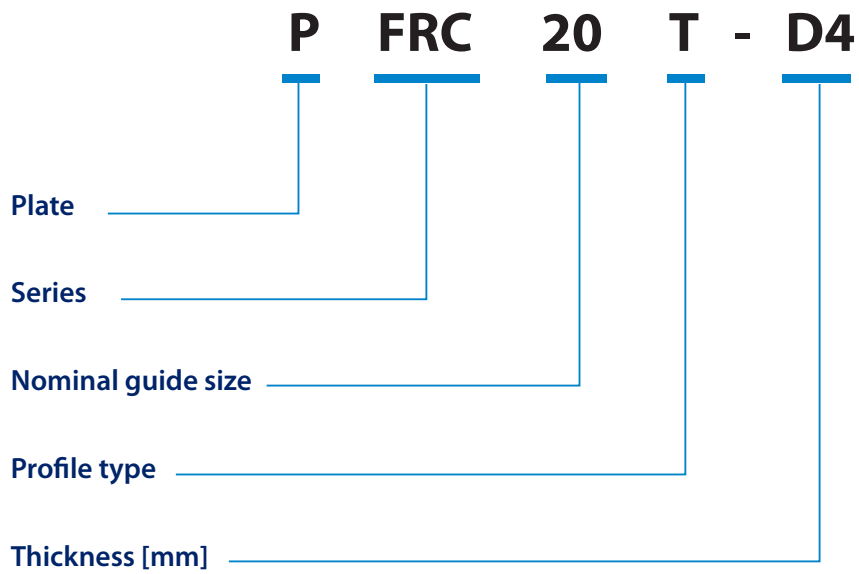

1.

The codes for the product Series are:

FRC	FRCMAN-M LT
FRCDP	FRCC
FRCDPH	FRCCMAN LT
FRCDPM	FRCBS
FRCMC	FRCMV
FRCMAN LT	FRC_SP

2.

Nominal guide size indicates the size of the guide rail on which the element is mounted. It is also the size of the element.

3.

The Profile type parameter refers to the linear guide profile. It also represents the profile of the body of the element in the clamping area.

Type	Profile
S	
T	

Table A

4.

The codes for the parameter Guide constructor are:

01 THK	09 DRYLIN	17 STAF	25 NORELEM
02 HIWIN	10 ROLLON	18 SKF	26 FRANKE
03 INA	11 NB	19 NITEK	27 WON
04 IKO	12 REXROTH-BOSCH	20 ROSA SISTEMI	28 IRSO
05 NSK	13 SCHNEEBERGER	21 SNR	29 THREE-R
06 ABBA	14 CPC	22 ALULIN	30 HEPKO
07 PMI	15 TBI	23 THOMSON	31 LEANTECHNIK
08 SBC	16 CSK	24 MISUMI	

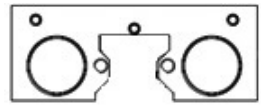
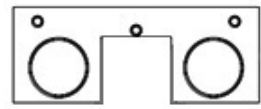
5.

The code for the pneumatic Working type parameter is composed as follows:

SE	Single action configuration "Normally Open" – Air to close
SEM	Single action configuration "Normally Closed" – Air to open
DE	Double action configuration "Normally Open" – Air to close and to open
DEM	Double action configuration "Normally Closed" – Air to open and to close

6.

Since every guide manufacturer supplies a wide range of guide models, the parameter "Guide-Block model" identifies in an univocal way the couple "guide model-block model".

7.

The final letter of the code identifies the element as "brake" or as "clamp".

B	Clamping element
F	Braking element

8.

For Special devices, built in order to meet customers' need, the code is followed by the letters "SP".

9.



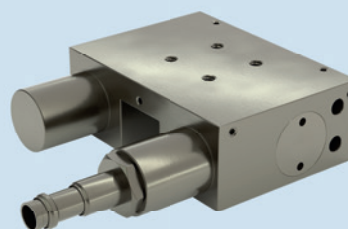

The element can be integrated with a proximity sensor in order to check the opening status. The sensor is a cylindrical inductive type, PNP or NPN. It is equipped with a connector and a cable. Operating Temp: $-25^{\circ}\text{C} \div +75^{\circ}\text{C}$



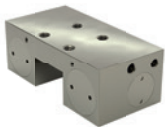
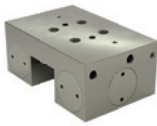
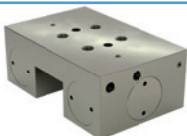
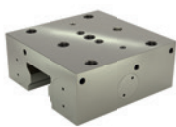

SERIES

CHARACTERISTICS

ELEMENTS FOR LINEAR GUIDES

	FRC	Basic clamping element Excellent force/dimension ratio
	FRCDP	Dual piston system High clamping force Small dimensions
	FRCDPH	Powered dual piston system Extremely high clamping force Small dimensions
	FRCDPM	Clamping and braking element High clamping force
	FRCMC	Single piston element Compact and inexpensive Suitable for small spaces
	FRCMAN LT	Manual element Practical and reliable New ergonomic design
	FRCMAN-M LT	Manual element for miniature guides New ergonomic design

ELEMENTS FOR ROUND GUIDES AND RODS

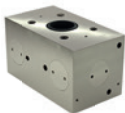
	FRCC	The same high performance of FRC line for round guides
	FRCCMAN LT	Manual element for round guides Practical and reliable New ergonomic design
	FRCBS	Dual piston system High clamping force

SPECIAL ELEMENTS

	FRCMV	Clamping system with only one contact element Small dimensions Multiple ways to use
	FRC_SP	Easy to assemble thanks to the decomposable system Independent piston system Shaped profile

HOW IT WORKS	AVAILABLE ALSO NORMALLY CLOSED	AVAILABLE AS A BRAKE	AVAILABLE WITH SENSOR	PAG.
PNEUMATIC UNIT	YES	YES	YES	10
PNEUMATIC UNIT	YES	YES	YES	12
PNEUMATIC UNIT	YES	YES	YES	14
PNEUMATIC UNIT	YES	YES	YES	16
PNEUMATIC UNIT	YES	YES	YES	18
MANUAL UNIT	NO	NO	NO	20
MANUAL UNIT	NO	NO	NO	22
PNEUMATIC UNIT	YES	YES	YES	24
MANUAL UNIT	NO	NO	NO	26
PNEUMATIC UNIT	YES	YES	YES	28
PNEUMATIC UNIT	YES	NO	YES	30
PNEUMATIC UNIT	YES	YES	NO	32

FRC Pneumatic Clamping Element

The tightening is done using an amplification system with inclined plane.
Made in construction steel, for high axial and horizontal stiffness.

FRC##\$ SE
FRC##\$ DE

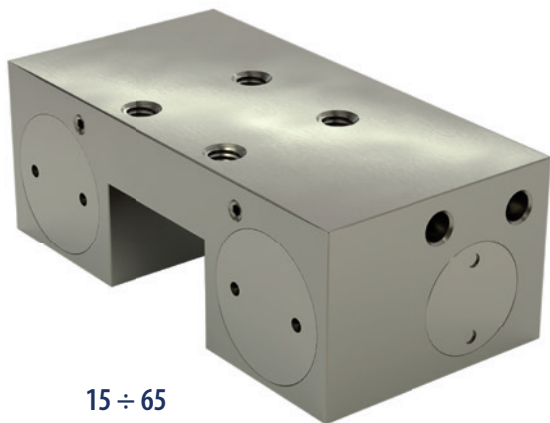

Guide size **15 ÷ 65**
\$ Guide type **T / S (see table A)**
Working type **Norm. Open**
Body **Steel**
Operating Temp. **-20°C ÷ 80°C**
Operating Pressure **5,5 ÷ 8 bar**

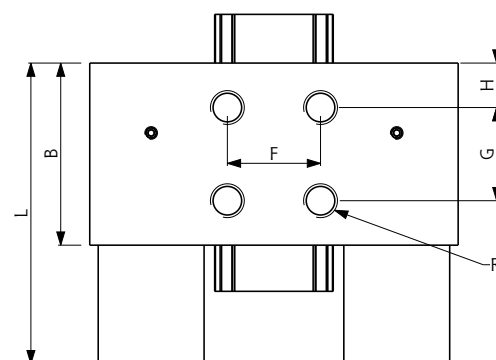
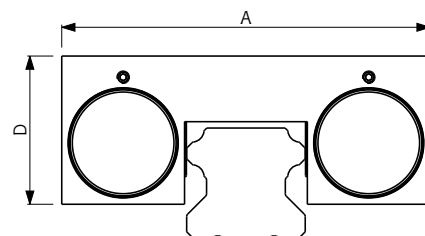

- ◆ Limited length
- ◆ High clamping forces
- ◆ Precise positioning
- ◆ High rigidity

Type	Guide	SEM	Clamping Force [N]			A [mm]	B [mm]
			SE	DE	DEM		
FRC	S 15	400	650	650	1050	57	43
FRC	T 15	400	650	650	1050	60	43
FRC	S 20	600	1000	1000	1600	68	39
FRC	T 20	600	1000	1000	1600	70	39
FRC	S 25	750	1200	1200	1950	75	39
FRC	T 25	750	1200	1200	1950	77	39
FRC	S 30	1050	1750	1750	2800	87	43
FRC	T 30	1050	1750	1750	2800	87	43
FRC	S 35	1250	2000	2000	3250	106	46
FRC	T 35	1250	2000	2000	3250	106	46
FRC	S 45	1500	2300	2300	3800	116	50
FRC	T 45	1500	2300	2300	3800	120	50
FRC	S 55	2000	3000	3000	5000	128	49
FRC	T 55	2000	3000	3000	5000	136	49
FRC	T 65	2000	3000	3000	5000	146	49

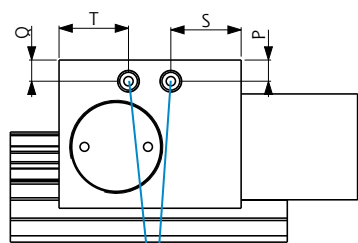

**M5
AIR CONNECTION**
we recommend
the use of compressed
air hose $\varnothing 6 \times 4$

FRC##\$ SEM
FRC##\$ DEM

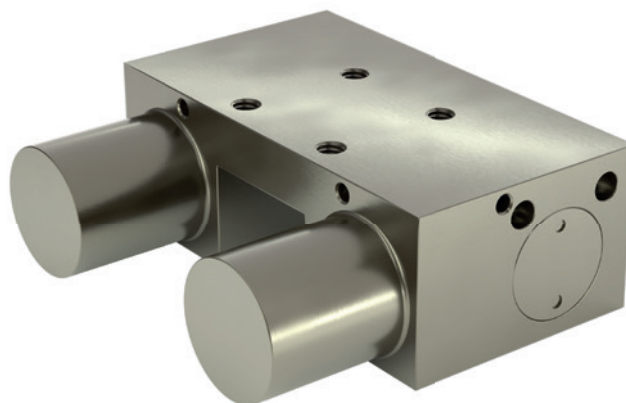

Guide size
\$ Guide type
Working type
Body
Operating Temp.
Operating Pressure

15 ÷ 65
T / S (see table A)
Norm. Closed
Steel
-20°C ÷ 80°C
5,5 ÷ 8 bar

- ◆ Locking element without the use of energy
- ◆ Includes springs for closing, while the pressure is for opening

D [mm]	F [mm]	G [mm]	H [mm]	L [mm]	P [mm]	Q [mm]	R	S [mm]	T [mm]
21	15	15	12.5	62	5	15	M4x5	37	6
21.5	15	15	12.5	62	5.5	15.5	M4x5	37	6
27	20	20	14	61	5	7	M5x5	16.9	5.5
25.5	20	20	14	61	5	5	M5x5	18.5	5
32.5	20	20	14	63.5	6.6	9.5	M6x8	19.5	5.5
28	20	20	14	63.5	5	6	M6x8	19	5.5
38.5	22	22	10.5	71	8.5	8.5	M8x8	16.5	16.5
35	22	22	10.5	71	5	5	M8x8	16.5	16.5
42.5	24	24	7.5	78	5.5	11	M8x15	23	7
42.5	24	24	7.5	78	12	11	M8x15	23	7
52	26	26	12	82	15	8	M10x19	20.5	21
52	26	26	12	82	15	8	M10x19	20	20
59	30	30	9.5	82	17	10	M10x19	18.5	18.5
54	30	30	9.5	82	13	8	M10x19	18.5	18.5
67	50	30	9.5	82	26	21	M10x20	18.5	18.5

FRCDP Double Piston Element

New line created to obtain a high clamping force in small spaces.
Dual Locking Action made by a pair of pistons for each tightening part.

FRCDP##\$ SE
FRCDP##\$ DE

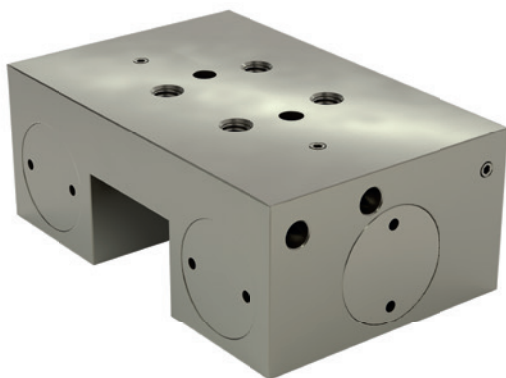

Guide size **20 ÷ 45**
 \$ Guide type **T / S (see table A)**
 Working type **Norm. Open**
 Body **Steel**
 Operating Temp. **-20°C ÷ 80°C**
 Operating Pressure **5,5 ÷ 8 bar**

- ◆ Dual piston system: high clamping force
- ◆ Small size
- ◆ Short reaction time

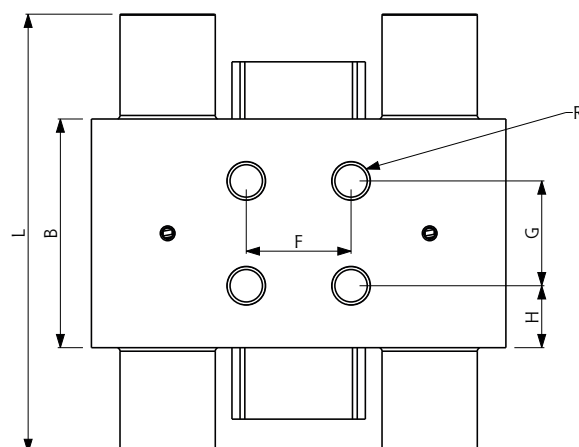
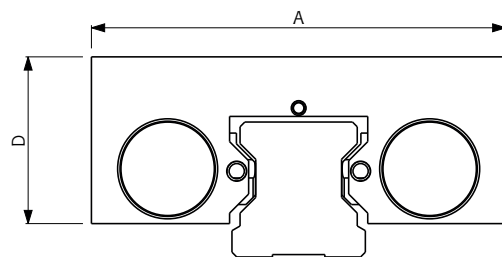

Type	Guide	Clamping Force [N]				A [mm]	B [mm]	D [mm]
		SEM	SE	DE	DEM			
FRCDP	S 20	800	1300	1300	2100	70	51	27
FRCDP	T 20	800	1300	1300	2100	73	51	25.5
FRCDP	S 25	1200	2000	2000	3200	74	51	32.5
FRCDP	T 25	1200	2000	2000	3200	78	51	30.5
FRCDP	S 30	1200	2000	2000	3200	87	48	35
FRCDP	T 30	1200	2000	2000	3200	89	48	33
FRCDP	S 35	1500	2200	2200	3700	94	49	44
FRCDP	T 35	1500	2200	2200	3700	100	49	36.5
FRCDP	S 45	2000	3000	3000	5000	107.8	56	52
FRCDP	T 45	2000	3000	3000	5000	120	56	43.5

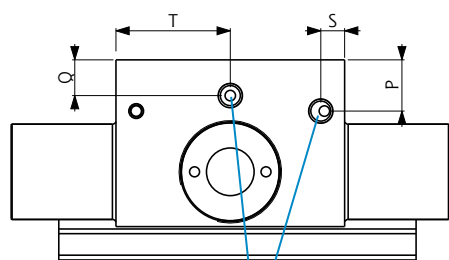

**M5
AIR CONNECTION**
we recommend
the use of compressed
air hose $\varnothing 6 \times 4$

**FRCDP##\$ SEM
FRCDP##\$ DEM**

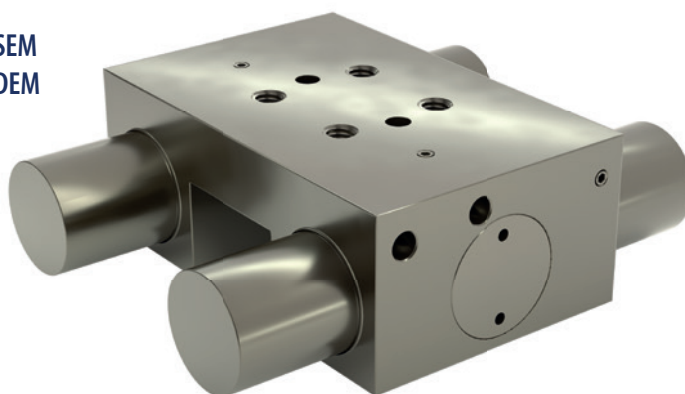

Guide size **20 ÷ 45**
 \$ Guide type **T / S (see table A)**
 Working type **Norm. Closed**
 Body **Steel**
 Operating Temp. **-20°C ÷ 80°C**
 Operating Pressure **5,5 ÷ 8 bar**

- ◆ Locking element without the use of energy
- ◆ High clamping force thanks to a double piston system
- ◆ Small size
- ◆ Short reaction times

F [mm]	G [mm]	H [mm]	L [mm]	P [mm]	Q [mm]	R	S [mm]	T [mm]
20	27	12	89	7.5	5	M5x6	15	10
20	27	12	89	5.5	5	M5x6	15	10
20	20	15.5	95	5.25	8.75	M6x7	25.5	5.5
20	20	15.5	95	5	6.5	M6x7	30.5	5.5
22	22	13	92	7.5	11	M8x10	24	5
22	22	13	92	6	9.5	M8x10	19.5	6
24	24	12.5	98	13	10	M8x15	14	19.5
24	24	12.5	98	7.5	5.25	M8x15	30.5	4.5
26	26	15	114	16.55	12.55	M10x17	28	4.5
26	26	15	114	13	9.5	M10x17	22	5

FRCDPH Powered Double Piston Element

New line created to obtain a high clamping force in small spaces.
 Powered Dual Locking Action: with a pair of pistons for each tightening part.
 The clamping force of this element is double that of FRC line.

FRCDPH##\$ SE
 FRCDPH##\$ DE

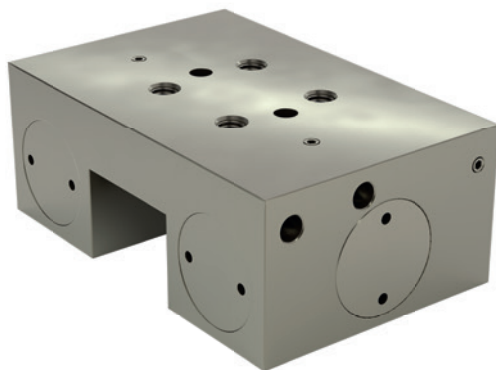

Guide size **15 ÷ 55**
 \$ Guide type **T / S (see table A)**
 Working type **Norm. Open**
 Body **Steel**
 Operating Temp. **-20°C ÷ 80°C**
 Operating Pressure **5,5 ÷ 8 bar**

- ◆ Dual piston system: high clamping force
- ◆ Small size
- ◆ Short reaction time

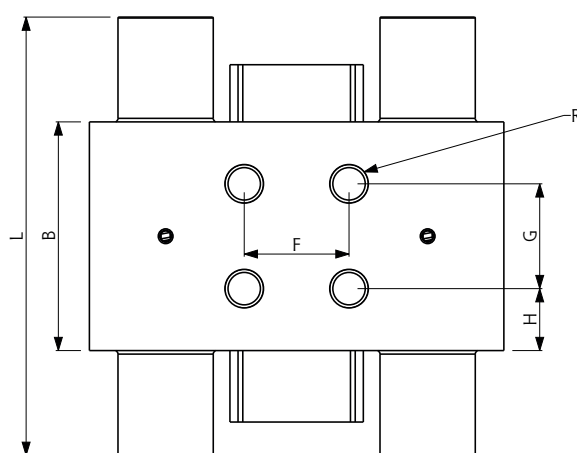
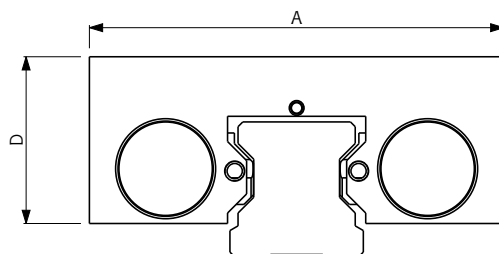

Type	Guide	Clamping Force [N]				A [mm]	B [mm]	D [mm]
		SEM	SE	DE	DEM			
FRCDPH	S 15	800	1300	1300	2100	61	54.4	21.5
FRCDPH	T 15	800	1300	1300	2100	61	54.4	21.5
FRCDPH	S 20	1200	2000	2000	3200	70	51	27
FRCDPH	T 20	1200	2000	2000	3200	73	51	25.5
FRCDPH	S 25	1500	2400	2400	3900	75	51	32.5
FRCDPH	T 25	1500	2400	2400	3900	78	51	32.5
FRCDPH	S 30	2100	3500	3500	5600	90	50	38
FRCDPH	T 30	2100	3500	3500	5600	93	50	38
FRCDPHL	S 35	2100	3500	3500	5600	97	50	40
FRCDPH	S 35	2500	4000	4000	6500	101	57.6	42
FRCDPHH	S 35	3000	4600	4600	7600	106	57.6	43.5
FRCDPH	T 35	2500	4000	4000	6500	109	60.8	42.3
FRCDPH	S 45	3000	4600	4600	7600	120	60.8	55
FRCDPH	T 45	3000	4600	4600	7600	120	60.8	49.3
FRCDPH	S 55	4000	6000	6000	10000	128	60	59
FRCDPH	T 55	4000	6000	6000	10000	136	60	54

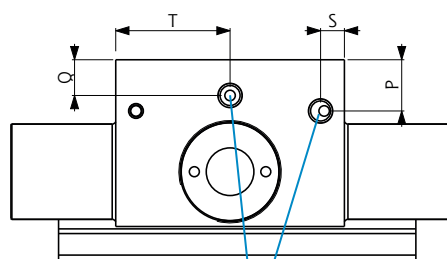

**M5
AIR CONNECTION**

we recommend
the use of compressed
air hose $\varnothing 6 \times 4$

**FRCDPH##\$ SEM
FRCDPH##\$ DEM**

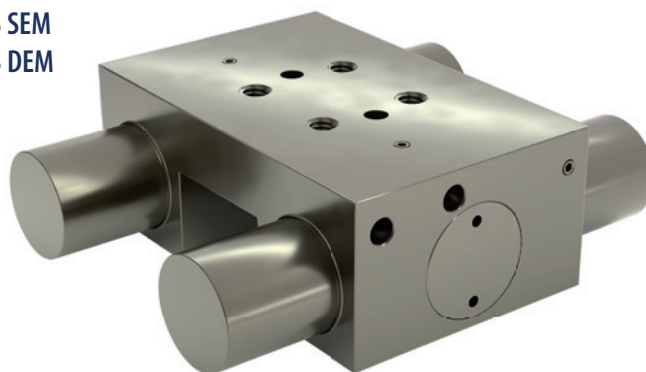

Guide size **15 ÷ 55**
 \$ Guide type **T / S (see table A)**
 Working type **Norm. Closed**
 Body **Steel**
 Operating Temp. **-20°C ÷ 80°C**
 Operating Pressure **5,5 ÷ 8 bar**

- ◆ Locking element without the use of energy
- ◆ High clamping force thanks to a double piston system
- ◆ Small size
- ◆ Short reaction times

F [mm]	G [mm]	H [mm]	L [mm]	P [mm]	Q [mm]	R	S [mm]	T [mm]
15	15	19.7	92.4	5	5	M4x4	16.2	16.2
15	15	19.7	92.4	5	5	M4x4	16.2	16.2
20	27	12	95	6.5	6.5	M5x6	16.1	15.8
20	27	12	95	5	5	M5x6	16.1	15.8
20	20	15.5	100	5	7.25	M6x7	25.5	5
20	20	15.5	100	5	7.25	M6x7	20.5	5
22	22	14	108	9	5	M8x10	12	25
22	22	14	108	9	5	M8x10	20.5	5
24	24	13	108	11	8	M8x15	25	12
24	24	16.8	97.6	10.5	6.5	M8x15	28.8	5
24	24	16.8	121.6	10.5	6.5	M8x15	28.8	6
24	24	18.4	124.6	7	5	M8x16	30.4	5
26	26	17.4	124.8	12	7	M10x18	30.4	5
26	26	17.4	124.8	12.3	7	M10x19	30.4	5
30	30	15	126	18	8	M10x20	30	23.5
30	30	15	126	13	8	M10x20	23.5	23.5

FRCDPM Clamping and Braking Element

Braking element with high clamping force.

Material and shape of contact parts allow high clamping force without damaging the rail.

FRCDPM##S SEM

FRCDPM##S DEM

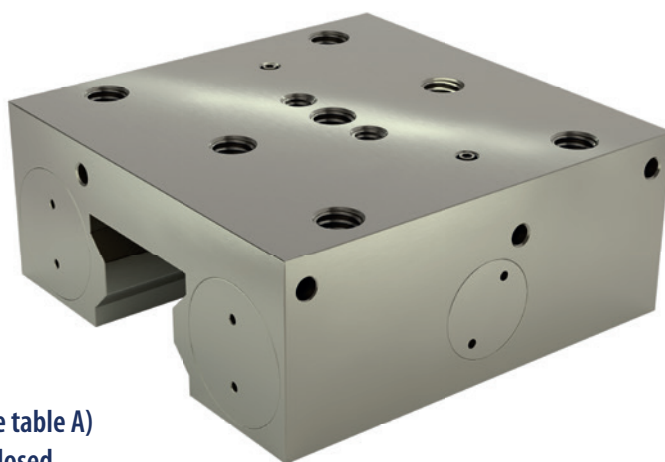

## Guide size	25 ÷ 35
\$ Guide type	T / S (see table A)
Working type	Norm. Closed
Body	Steel
Operating Temp.	-20°C ÷ 80°C
Operating Pressure	5,5 ÷ 8 bar

- ◆ Locking element without the use of energy
- ◆ High clamping force thanks to a double piston system
- ◆ Short reaction times
- ◆ Compact and rigid body
- ◆ Clamping in case of pressure drop
- ◆ Working in emergency stop

Type	Guide	Clamping Force [N]		A [mm]	B [mm]	D [mm]	F [mm]	G [mm]
		SEM	DEM					
FRCDPM	S 25	1500	3900	70	99	32.5	57	22.5
FRCDPM	S 30	2100	5600	90	109	38	72	22
FRCDPM	S 35	2600	6600	100	100.6	42	82	31
FRCDPM	T 35	2600	6600	108	100.6	42	82	31

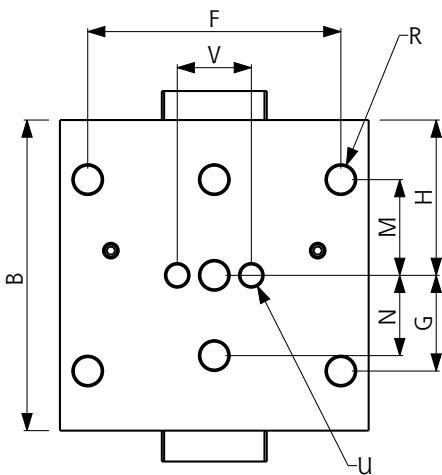
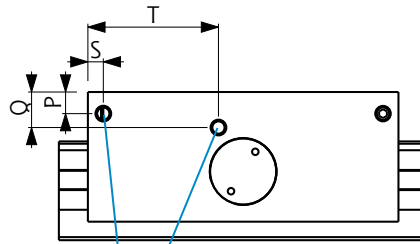
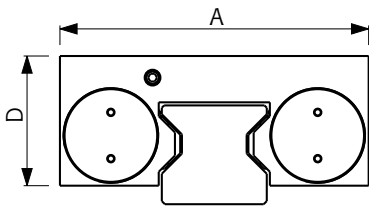

**M5
AIR CONNECTION**
we recommend
the use of compressed
air hose \varnothing 6x4

H [mm]	M [mm]	N [mm]	P [mm]	Q [mm]	R	S [mm]	T [mm]	U	V [mm]
49.5	22.5	20	7.75	5.25	M8x7	5	56	M6x7	20
54.5	26	22	9	6	M10x8	5	47	M8x8	22
50.3	31	26	7	11.5	M10x10	5	42.3	M8x10	24
50.3	31	26	7	11.5	M10x10	5	42.3	M8x10	24

FRCMC Single Cylinder Element

Compact and inexpensive locking element.

These characteristics are obtained using a single contact section.

The clamping action is allowed by the floating system of the body that ensures:

- the clamping of the rail on one side by the contact section and on the other by the body itself;
- a symmetrical distribution of clamping force on the linear guide;
- absolutely no friction between the linear guide with the body and with the contact section when the clamping is released.

FRCMC##\$ SE
FRCMC##\$ DE

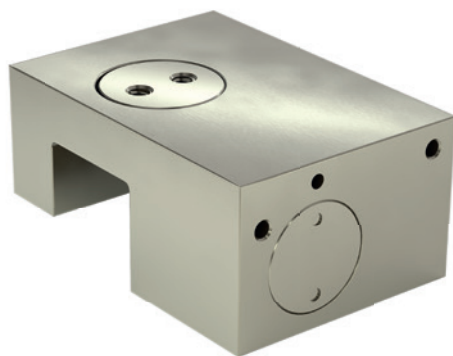

Guide size **15 – 20 – 25**
 \$ Guide type **T / S (see table A)**
 Working type **Norm. Open**
 Body **Steel**
 Operating Temp. **-20°C ÷ 80°C**
 Operating Pressure **5,5 ÷ 8 bar**

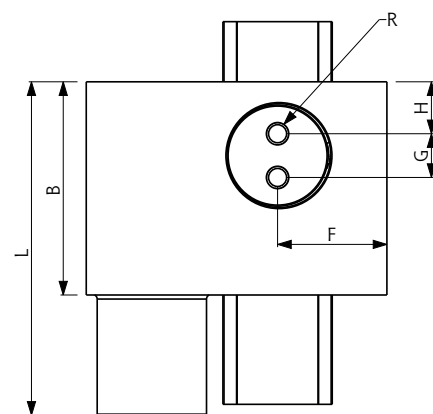
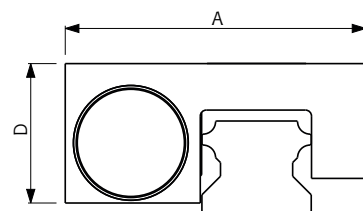

Type	Guide	Clamping Force [N]				A [mm]	B [mm]	D [mm]
		SEM	SE	DE	DEM			
FRCMC	T 15	200	320	320	520	41.5	36	18
FRCMC	S 20	300	500	500	800	55	39	27
FRCMC	T 20	300	500	500	800	55	39	25.5
FRCMC	S 25	375	600	600	975	60.5	39	30
FRCMC	T 25	375	600	600	975	60.5	39	30

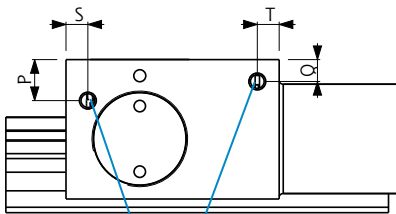

M3

AIR CONNECTION

we recommend
the use of compressed
air hose $\varnothing 6 \times 4$

FRCMC##\$ SEM
FRCMC##\$ DEM



Guide size
\$ Guide type
Working type
Body
Operating Temp.
Operating Pressure

15 – 20 – 25
T/S (see table A)
Norm. Closed
Steel
-20°C ÷ 80°C
5,5 ÷ 8 bar

F [mm]	G [mm]	H [mm]	L [mm]	P [mm]	Q [mm]	R	S [mm]	T [mm]
14.25	7	8.9	55	4	4	M4x4.5	3	4.5
21	8	9.5	61	5	4	M4x5.8	4	4
21	8	9.5	61	5	4	M4x5.8	4	4
22	8	9.5	63.5	5	7.5	M4x5.8	5	5
22	8	9.5	63.5	5	7.5	M4x5.8	5	5

FRCMAN LT Manual Clamping Element for Linear

Simple and reliable, this clamping element is manually controlled.

By acting on the adjustable locking lever, the contact profiles press with sync on the surfaces of the rail.

The floating profiles of contact ensure a symmetrical distribution of the force on the linear guide.

New ergonomic design.

FRCMAN ##\$ LT

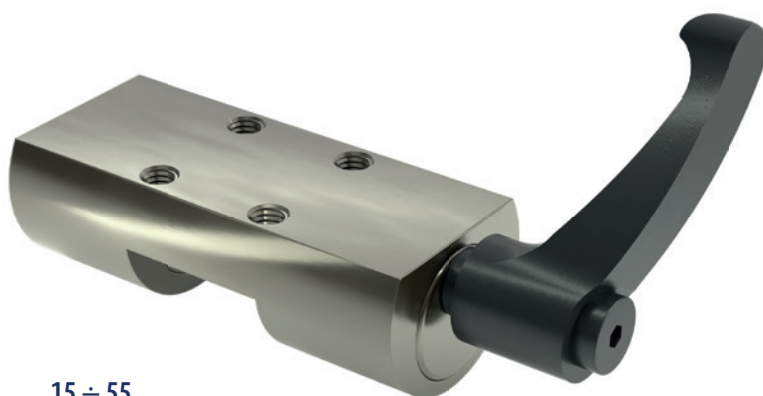

## Guide size	15 ÷ 55
\$ Guide type	T / S (see table A)
Working type	Manual
Body	Steel

- ◆ Simple and inexpensive
- ◆ Floating locking contacts

Type	Guide	Clamping Force [N]	A [mm]
FRCMAN LT	S 15	1200	47
FRCMAN LT	T 15	1200	47
FRCMAN LT	S 20	1200	60
FRCMAN LT	T 20	1200	60
FRCMAN LT	S 25	1200	70
FRCMAN LT	T 25	1200	70
FRCMAN LT	S 30	2000	90
FRCMAN LT	T 30	2000	90
FRCMAN LT	S 35	2000	98
FRCMAN LT	T 35	2000	98
FRCMAN LT	S 45	2000	118
FRCMAN LT	T 45	2000	118
FRCMAN LT	T 55	2000	138

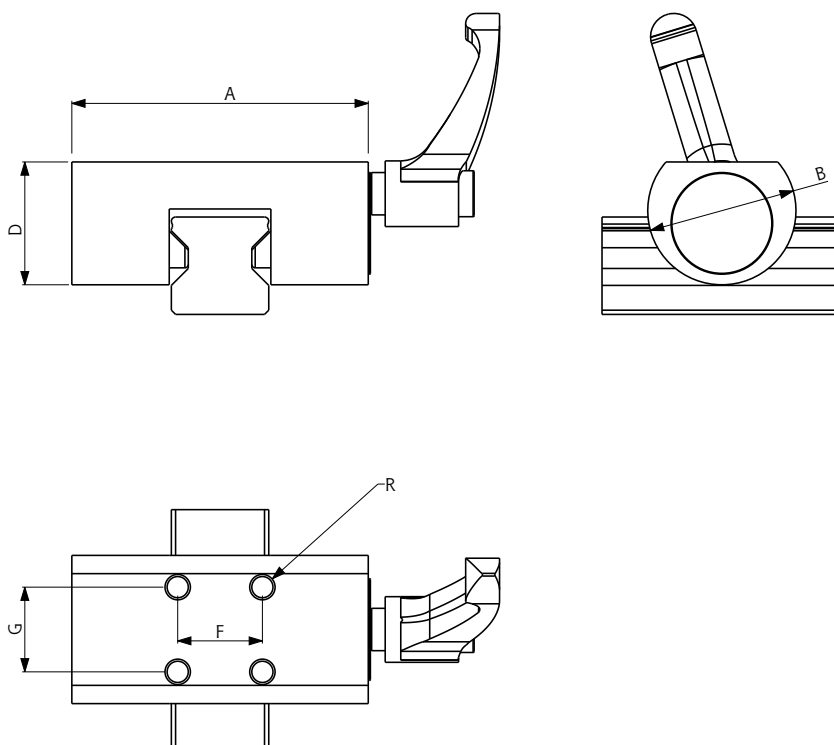

B [mm]	D [mm]	F [mm]	G [mm]	R
25	19	17	17	M4x5
25	17.5	17	17	M4x5
28	23	15	15	M5X6
26	20	15	15	M5X6
35	29	20	20	M6x7
32	24	20	20	M6x7
40	32	22	22	M6x8
38	29	22	22	M6x8
45	37	24	24	M8x10
42	32	24	24	M8x10
55	48	26	26	M10x14
50	42	26	26	M10x14
56	47	30	30	M14x16

FRCMAN-M LT for Miniature Linear Guides

Manual clamping element for miniature linear guides.

By acting on the locking screw, the contact sections press with sync on the surfaces of the rail.

The floating profiles of contact ensure a symmetrical distribution of the force on the linear guide.

New ergonomic design to save space.

FRCMAN ## M LT

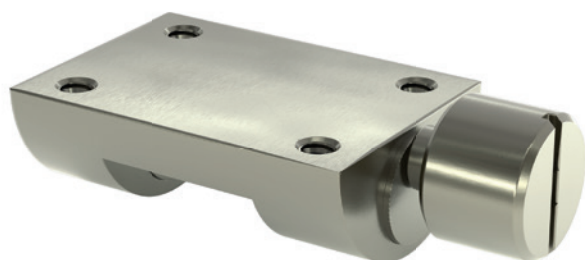

## Guide size	9 ÷ 15
Working type	Manual
Body	Steel

- ◆ Simple and inexpensive
- ◆ Floating locking contacts

Type	Size	Clamping Force [N]	A [mm]	B [mm]
FRCMAN-M LT	7	65	17	12
FRCMAN-M LT	9	100	20	17
FRCMAN-M LT	12	150	27	19
FRCMAN-M LT	15	180	32	20

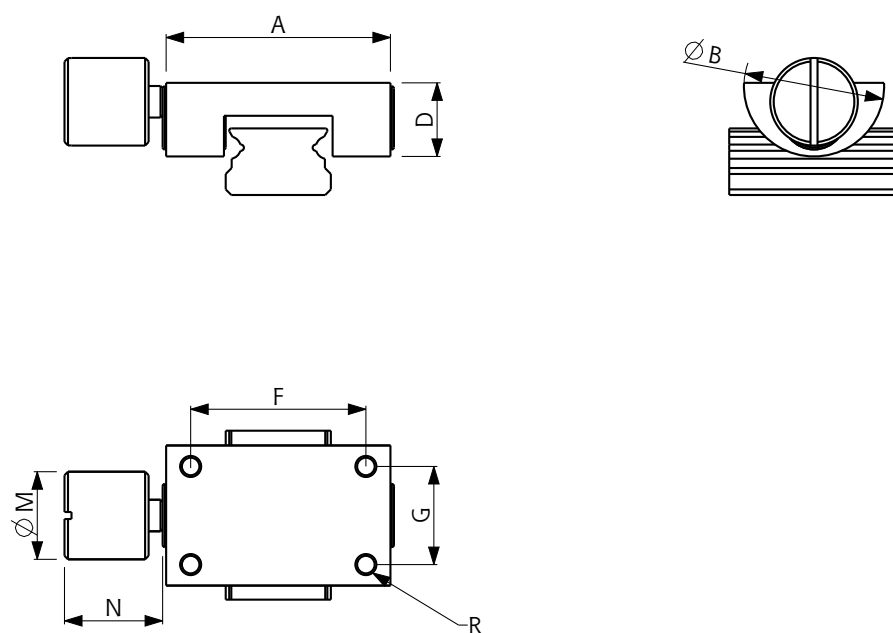

D [mm]	F [mm]	G [mm]	M [mm]	N [mm]	R
6	12	8	6	7,5	M2X3
7.3	15	11	8	9	M3x3
9.5	20	13	10	10	M3x4.5
10.5	25	14	12.5	14	M5X6

FRCC Pneumatic Clamping Elements for Round Bars

The same high performance of FRC line for round guides
The tightening is done using an amplification system with inclined plane.

FRCC##SE
FRCC##DE

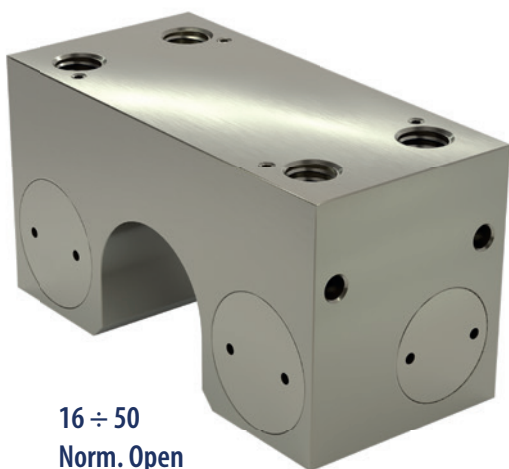

Guide size
Working type
Body
Operating Temp.
Operating Pressure

16 ÷ 50
Norm. Open
Steel
-20°C ÷ 80°C
5,5 ÷ 8 bar

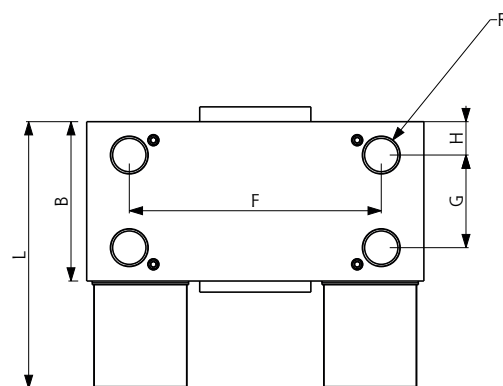
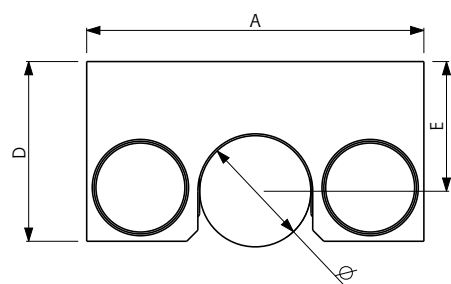

Type	Ø guide	Clamping Force [N]				A [mm]	B [mm]	D [mm]
		SEM	SE	DE	DEM			
FRCC	16	400	650	650	1050	55	35	31.5
FRCC	20	600	1000	1000	1600	66	38	36.5
FRCC	25	750	1200	1200	1950	77	38.5	43
FRCC	30	1050	1750	1750	2800	91	43	48.5
FRCC	40	1500	2300	2300	3800	115	49	63
FRCC	50	2000	3000	3000	5000	131	48	70

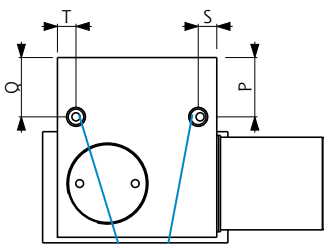
M5
AIR CONNECTION

we recommend
the use of compressed
air hose \varnothing 6x4

FRCC##SEM
FRCC##DEM

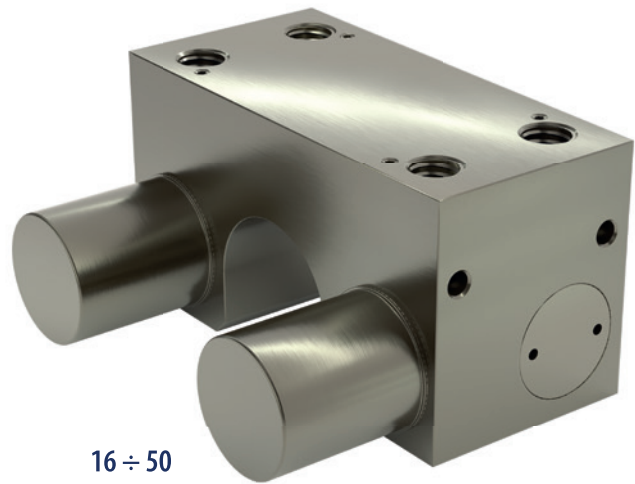

Guide size
Working type
Body
Operating Temp.
Operating Pressure

16 ÷ 50
Norm. Closed
Steel
-20°C ÷ 80°C
5,5 ÷ 8 bar

E [mm]	F [mm]	G [mm]	H [mm]	L [mm]	P [mm]	Q [mm]	R	S [mm]	T [mm]
22	15	15	10	54	11.65	11.65	M5x6	5	5
25	45	18	13	60	12.5	12.5	M8x10	13.5	5
30	60	20	8	63	10.5	15.5	M10x12	5	5
35	68	25	9	72	16	16	M10x12	5	5
45	90	26	9	81	20	20	M10x15	5	17
50	108	30	9	81	21.5	21.5	M10x15	5	5

FRCCMAN LT Manual Clamping Element for Round

Simple and reliable, this clamping element is manually controlled.

By acting on the adjustable locking lever, the contact profiles press with sync on the surfaces of the bar.

The floating profiles of contact ensure a symmetrical distribution of the force on the round bar or guide.

New ergonomic design.

FRCCMAN## LT



Guide size **12 ÷ 50**
 Working type **Manual**
 Body **Steel**

- ◆ **Simple and inexpensive**
- ◆ **Floating locking contacts**

Type	Ø guide	Clamping Force [N]	A [mm]	B [mm]
FRCCMAN LT	12	1200	43	30
FRCCMAN LT	16	1200	47	30
FRCCMAN LT	20	1200	60	32
FRCCMAN LT	25	1200	70	40
FRCCMAN LT	30	2000	90	45
FRCCMAN LT	40	2000	107	58
FRCCMAN LT	50	2000	130	65

Bars – LIGHT LINE

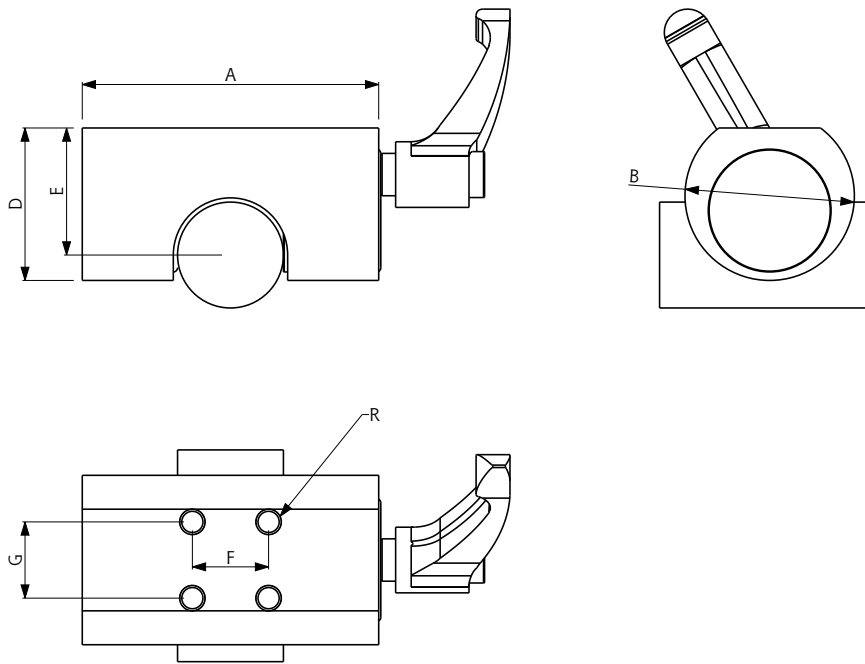

D [mm]	E [mm]	F [mm]	G [mm]	R
24	18	17	17	M4x5
26	22	17	17	M4x5
28	25	15	15	M5X6
36	30	18	18	M6x8
41	35	20	20	M6x8
51	45	25	25	M10x15
55	50	30	30	M14x20

FRCBS Braking Element For Rods

The body of the element made in anodized aluminium improve the mechanical properties of this device.

The double piston system produces clamping forces that are 50% higher than the normal mechanism, maintaining a limited size.

FRCBS##SE
FRCBS##DE

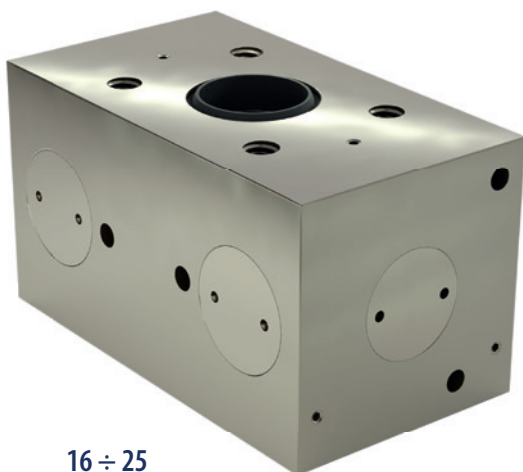

Rod diameter **16 ÷ 25**
 Working type **Norm. Open**
 Body **Anodized aluminum**
 Operating Temp. **-20°C ÷ 80°C**
 Operating Pressure **5,5 ÷ 8 bar**

- ◆ Compact in size
- ◆ Functioning in both directions
- ◆ High clamping force thanks to a double piston system

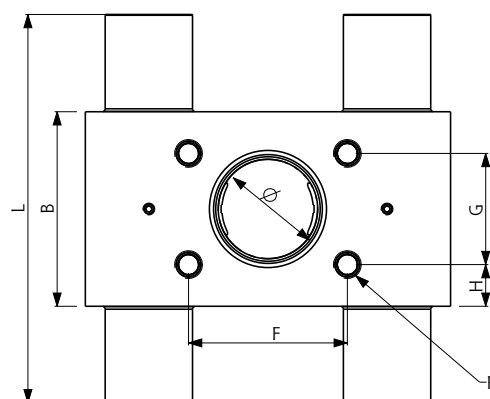
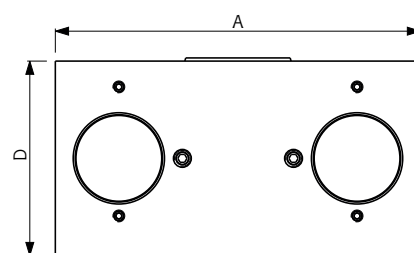

Type	Ø guide	Clamping Force [N]				A [mm]	B [mm]
		SEM	SE	DE	DEM		
FRCBS	16	1200	1600	1600	2800	83	49
FRCBS	20	1200	1800	1800	3000	87	49
FRCBS	25	1500	2000	2000	3500	92	49

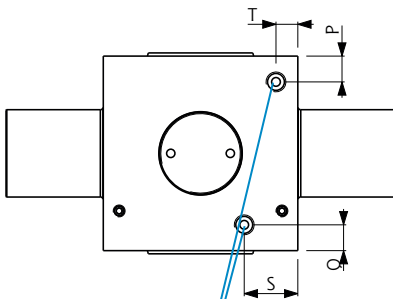
M5
AIR CONNECTION

we recommend
the use of compressed
air hose $\varnothing 6 \times 4$

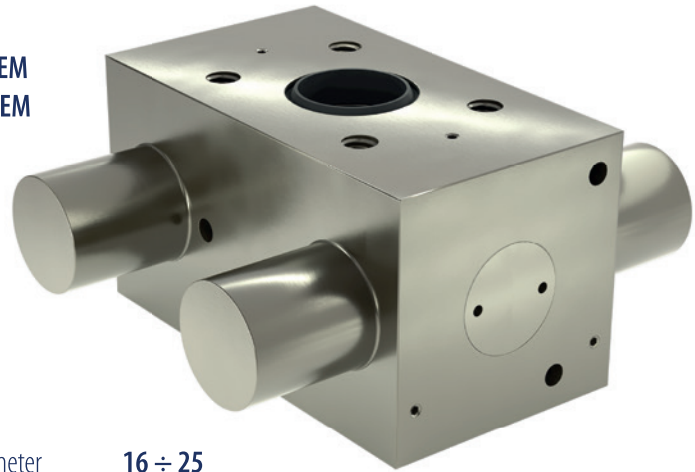
FRCBS##SEM
FRCBS##DEM

## Rod diameter	16 ÷ 25
Working type	Norm. Closed
Body	Anodized aluminum
Operating Temp.	-20°C ÷ 80°C
Operating Pressure	5,5 ÷ 8 bar

- ◆ **Compact in size**
- ◆ **Double piston system**
- ◆ **Used to block guided loads in case of pressure drop (emergency situations)**
- ◆ **The clamping force operates in both directions**

D [mm]	F [mm]	G [mm]	H [mm]	L [mm]	P [mm]	Q [mm]	R	S [mm]	T [mm]
49	40	28	10.5	98	6.5	6.5	M6x6	13.5	5.5
49	40	28	10.5	98	6.5	6.5	M6x6	13.5	5.5
49	40	28	10.5	98	6.5	6.5	M6x6	13.5	5.5

ERRE.DI. Automation also provides special elements to best meet customers' needs

Thanks to its advanced technical know-how and a continuous process of innovation, ERRE.DI. is able to provide customized automation components to best meet its customers' needs, creating a real partnership during the development of new solutions.

Design, manufacturing and testing are carried out within ERRE.DI. facilities in order to give a quick and effective response to customers' requests. Here below some examples of customized solutions.

FRCMV Multifunction Element

FRCMV##SE
FRCMV##DE

FRCMV##SEM
FRCMV##DEM



Size **15**
Working type **Norm. Open**
Body **Steel/Aluminum**
Operating Temp. **-20°C ÷ 80°C**
Operating Pressure **5,5 ÷ 8 bar**

Size **15**
Working type **Norm. Closed**
Body **Steel/Aluminum**
Operating Temp. **-20°C ÷ 80°C**
Operating Pressure **5,5 ÷ 8 bar**

- ◆ Small dimensions
- ◆ Multiple ways to use
- ◆ Different fields of application
- ◆ Also available with the contact elements covered with rubber

Type	Size	Clamping Force [N]				A [mm]	A1 [mm]	B [mm]	D [mm]	F [mm]	F1 [mm]	G [mm]
		SEM	SE	DE	DEM							
FRCMV	15	200	320	320	520	20.7	21.22	43	25	14.5	18	14

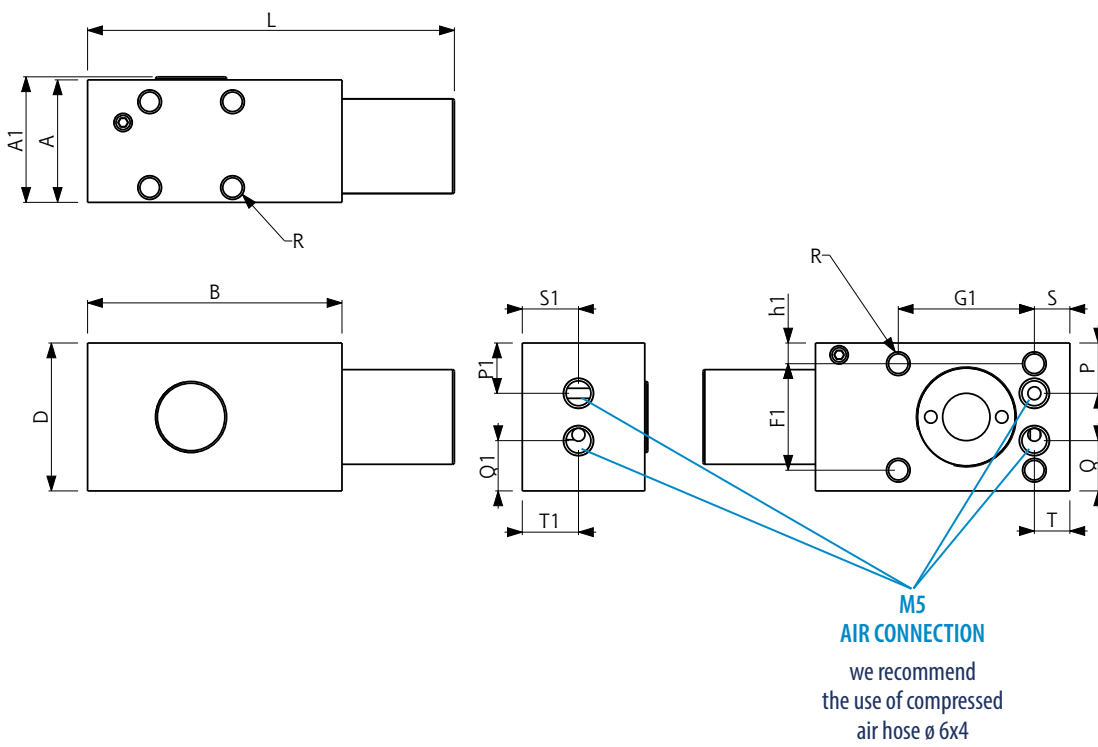

G1 [mm]	H [mm]	h [mm]	h1 [mm]	L [mm]	P [mm]	Q [mm]	R	S [mm]	T [mm]	P1 [mm]	Q1 [mm]	S1 [mm]	T1 [mm]
23	10.5	2.5	3.5	62	8.5	8.5	M4X4	6	6	8.5	8.5	9.5	9.5

FRC_SP Decomposable Clamping Element

It's a small element, extremely easy to install and/or replace in the system where is used:

- Fewer parts of the production machine need to be displaced;
- No need to slide the blocking element along the whole length of the guide.

FRC##S01SE_SP
FRC##S01SEM_SP

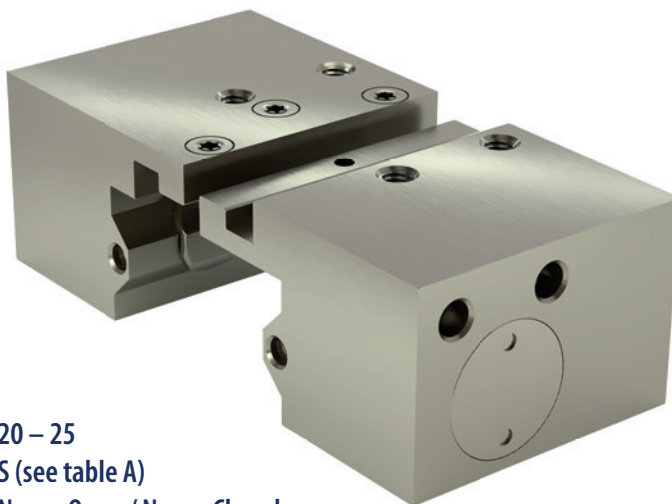

## Guide size	20 – 25
\$ Guide type	S (see table A)
Working type	Norm. Open / Norm. Closed
Body	Steel
Operating Temp.	-20°C ÷ 80°C
Operating Pressure	5,5 ÷ 8 bar

- ◆ Single-piston system
- ◆ Reduced length
- ◆ High clamping forces
- ◆ Precise positioning
- ◆ High rigidity
- ◆ Shaped profile

Note



Note

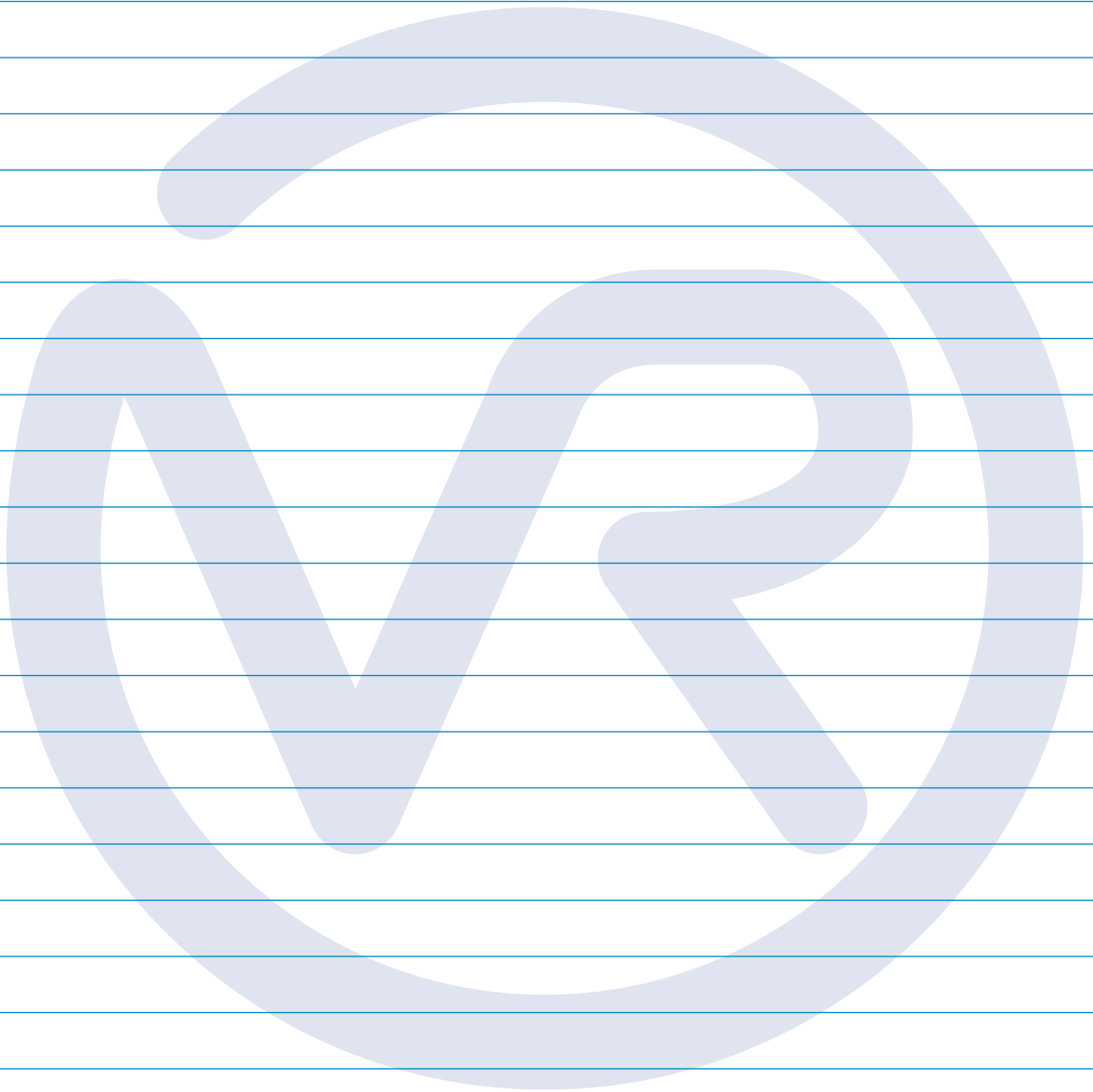

Note





ERRE.DI. s.r.l.

Offices and production:

Via Dei Lavoratori, 15 - 20092 Cinisello Balsamo (MI) - Italy

Tel. (+39) 02 66040229 Fax (+39) 02 6128041

www.erredisrl.it - sales@erredisrl.it